

STANDARD
 350ohm STRAIN GAGE INPUT
 SCALEABLE RANGE
 2 CONFIGURABLE ALARMS
 HIGH/LOW/OFF
 AUTO / MANUAL CALIBRATION
 MANUAL ZERO
 LOCKOUT
 PROCESS VALUE - RETRANS

MODEL CODE
 MP9410-PRR -

RETRANS of PV	
M	4-20mA
0	0-10mA
1	0-20mA
5	0-5V
6	1-5V
10	0-10V



MP9610 - PRESSURE INDICATOR ALARM - 1/4DIN

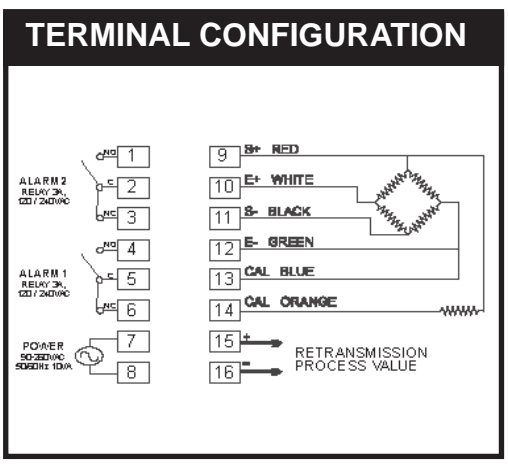

STANDARD
 350ohm STRAIN GAGE INPUT
 SCALEABLE RANGE
 2 CONFIGURABLE ALARMS
 HIGH/LOW/OFF
 AUTO/MANUAL CALIBRATION
 MANUAL ZERO
 LOCKOUT
 PROCESS VALUE - RETRANS

MODEL CODE
 MP9610-PRR -

RETRANS of PV	
M	4-20mA
0	0-10mA
1	0-20mA
5	0-5V
6	1-5V
10	0-10V



SPECIFICATIONS - MP9410 & MP9610

INPUT - PRESSURE TRANSDUCER
 350ohm STRAIN GAUGE 2.00-4.00mV/V standard 3.30mV/V
 EXCITATION VOLTAGE 10VDC
 ACCURACY +/-0.5%
 SAMPLE RATE 100ms

ALARM OUTPUTS
 ALARM 1 5A/240VAC resistive NO/NC
 ALARM 2 5A/240VAC resistive NO/NC

RETRANSMISSION of PROCESS VALUE
 CURRENT 4-20mA, 0-20mA, 0-10mA Max load 500 ohm
 VOLTAGE 0-5VDC, 1-5VDC Max 20mA

POWER
 RATING 85 - 265 VAC 50/60Hz 10VA max

ENVIRONMENTAL
 OPERATING TEMP -10 - 50C
 HUMIDITY 90% MAX
 INSULATION 20M ohms minimum @ 500VDC
 WEIGHT 300g

PHYSICAL DIMENSIONS
 MP9410 96mmW x 48mmH x 100mmD
 MP9410 Cutout 91mmW x 45mmH +/-0.5mm
 MP9610 96mmW x 96mmH x 100mmD
 MP9610 Cutout 91mmW x 91mmH +/-0.5mm